



IT Sollevatore elettroidraulico mobile a forbice, ideale per la rimozione e installazione di motori e batterie.

EN Mobile electro-hydraulic scissor lift suitable for mounting or removing batteries and vehicle components.

FR Élévateur à ciseaux électro-hydraulique mobile, idéal pour l'installation et le retrait de batteries et composants de véhicule

DE Mobiler Scherenhubtisch. Ideal zum Ein- und Ausbau von Batterie und Fahrzeugkomponenten.

ES Elevador móvil de tijera electrohidráulico ideal para instalar y enlevar baterías y componentes de vehículos



IT Regolazione dell'inclinazione del piano tramite telecomando.

EN Table inclination adjustment by remote control.

FR Réglage de l'inclinaison de table par télécommande.

DE Verstellung der Neigung des Schiene per Fernbedienung.

ES Ajuste de la mesa basculante por mando a distancia.



IT Sicurezza meccanica con valvola sul cilindro. Valvola controllo velocità di discesa.

EN Mechanical safety with valve on the cylinder. Lowering speed control valve.

FR Sécurité mécanique avec valve sur le cylindre. Soupape de régulation de vitesse de descente

DE Mechanische Sicherheit mit Ventil am Zylinder. Sinkgeschwindigkeitsregelventil.

ES Seguridad mecánica con válvula en el cilindro. Válvula de control de velocidad de bajada.

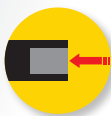

IT Vano posteriore estraibile **EN** Removable rear compartment
FR Compartiment arrière amovible **DE** Herausnehmbares Heckfach. **ES** Compartimiento trasero extraíble.

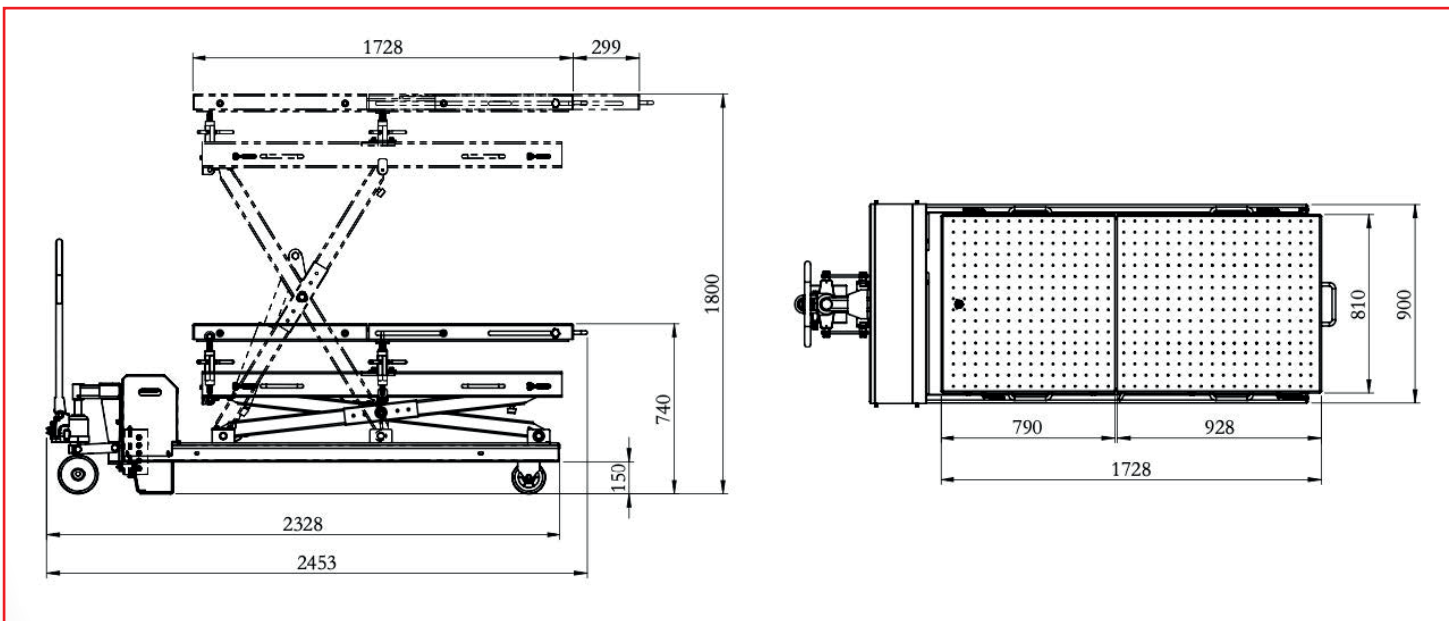

Dati tecnici • Technical data • Données techniques • Technisches Daten • Datos técnicos

<ul style="list-style-type: none"> • Portata massima • Capacity • Capacité de charge • Tragfähigkeit • Capacidad 	<ul style="list-style-type: none"> • Altezza max • Maximum height • Hauteur maxi • Maximalhöhe • Altura máxima 	<ul style="list-style-type: none"> • Altezza min • Minimum height • Hauteur minimum • Minimalhöhe • Altura mínima 	<ul style="list-style-type: none"> • Alimentazione • Power supply • Alimentation • Stromversorgung • Alimentación 	<ul style="list-style-type: none"> • Tempo di sollevamento • Lifting time • Temps de soulèvement • Heben Zeit • Duración de elevación 	<ul style="list-style-type: none"> • Peso netto • Net weight • Poids net • Nettogewicht • Peso neto
1500 Kg	1800 mm	740 mm	230V 50-60Hz 1ph	29 sec	750 Kg

L'azienda si riserva di modificare le caratteristiche dei prodotti in qualsiasi momento. The manufacturer reserves the right to modify the features of the products at any time.



CORMACH SRL Correggio Machinery

Via A. Pignedoli, 2
 42015 Correggio (RE) Italy
 cormach@cormachsr.com

Tel. +39 0522/631274
 Fax +39 0522/631284

www.cormachsr.com

