



Operating Instruction

Mobile Wheel Carriage Master Wheel 50



Type

Serial number

Date

Operating Instruction

Table of Contents

Table of Contents

1	Safety	2
1.1	Safety instructions in this manual	2
2	Introduction	3
2.1	Areas of operation.....	3
2.2	Warranty and liability	3
2.3	Safety / accident prevention.....	3
2.4	Instructions for adhering to the operating instructions	4
2.5	Operator obligations.....	4
2.6	Dangers in handling the Master Wheel 50.....	4
2.7	Maintenance work, repairing faults, disposal	5
2.8	Special dangers.....	5
3	Technical data	6
4	Transport and assembly	7
4.1	Assembling the feet.....	7
4.2	Assembling the sliding handle	7
4.3	Assembling the wheel support	7
5	Commissioning	7
6	Operation	8
6.1	Charging the battery.....	8
6.2	Loading and unloading	8
6.3	Transporting the load	8
6.4	Lifting loads	9
6.5	Lowering loads	9
7	Faults / causes / rectification	10
8	Maintenance and repair	11
8.1	Electrical circuit diagram.....	11
8.2	Periodic work.....	11
8.3	Description of periodic work	11
9	Safety examination	13
10	Appendix	14
10.1	Adhesive notices.....	14
10.2	Safety examination	15

1 Safety

1.1 Safety instructions in this manual



Danger
Risk to life and limb.



Warning
Material damage.



Information and tips.

2 Introduction

Blitz lifting tools are the result of many years of experience. The high quality standards and the well-considered concept guarantee reliability, durability and economic operations. Please read these operating instructions carefully and adhere at all times to the contents in order to avoid unnecessary damage and risks.

2.1 Areas of operation

The Master Wheel 50 is exclusively designed to lift, lower and transport car tyres in car garages. In this, the load must not exceed the load bearing capacity of the appliance. The appliance must not be used in areas that are exposed to the risk of explosion.



Warning

Any other use, or any use that exceeds the described scope, is deemed to be improper. This applies in particular to climbing on to the appliance, driving with the appliance or using it as a support stand.

BlitzRotary GmbH will not be made liable for damage that results from improper use. The operator carries the exclusive risk for this.

The following is also deemed necessary for proper use

- Adherence to all instructions in these operating instructions
- Adherence to inspection and maintenance work and the specified tests.

2.2 Warranty and liability

Our "General terms of sales and supply" apply. The operator has been in possession thereof since the conclusion of the contract. Warranty and liability claims for personal and material damage are excluded if they are based on one or more of the following circumstances:

- Improper use.
- Improper assembly, commissioning, operation and maintenance of the appliance.
- Operation of the Master Wheel 50 while the safety installations are defect or improperly installed or non-functioning safety and protective installations.
- Failure to adhere to the instructions in the operating instructions concerning transport, storage, assembly, operation and maintenance.
- Customer modifications to the Master Wheel 50.
- Substandard monitoring of parts that are subject to wear.
- Improperly implemented repairs.
- Catastrophes due to the influence of foreign bodies or acts of god.

We will not accept customer services claims or the costs of return transport in the event of there being a failure to adhere to these listed points. Therefore, please contact the manufacturing plant before organising any return transport.

2.3 Safety / accident prevention

The Master Wheel 50 must only be operated by qualified persons. Unauthorised persons are prohibited from operating the appliance!

Operating Instruction

Introduction

2.4 Instructions for adhering to the operating instructions

- Knowledge of the fundamental safety instructions and the safety regulations is a basic precondition for safe handling and undisturbed operation of the short lifter.
- The operating instructions must be adhered to by all persons that work on the short lifter. This applies in particular to the chapter on "Safety / accident prevention".
- The rules and regulations that apply at the place of operation must also be adhered to in addition to the safety instructions in the operating instructions.

2.5 Operator obligations

The operator is obligated to only allow such persons to work on the system as

- are aware of the fundamental regulations concerning work safety and accident prevention and have been instructed in the handling of the system
- have read, understood and confirmed by signature the safety chapter and warnings in these operating instructions.

2.6 Dangers in handling the Master Wheel 50



Danger

The Master Wheel 50 must only be operated for its designated purpose in perfect and safe working order. Faults that may affect the safety must be rectified immediately.

The appliances are designed and constructed on the basis of state of the art technology and the recognised technical safety regulations. Nonetheless, improper use may result in a risk for the life and limb of the operator or in material damage.

- Never operate the appliance in areas that are exposed to the risk of explosion.
- Only use the appliance on an even, firm surface.
- Only move the appliance when this would not endanger any persons.

- Keep the area in which the Master Wheel 50 moves free.
- Persons must not enter the area in which the Master Wheel 50 moves!
- Do not exceed the maximum load bearing capacity.
- Do not climb on to the Master Wheel 50, travel with it or climb on to the load!
- Carry out lifting, lowering and moving evenly. Observe the load during transport.

Organisational measures

- Keep the operating instructions accessible at all times at the place of operation of the short lifter.
- In addition to the operating instructions, general statutory and other binding regulations concerning accident prevention and environmental protection must be observed and publicised!
- Monitor at least occasionally during operation that the staff operate the appliance in accordance with the safety and danger instructions!
- Use personal safety equipment whenever necessary or specified in regulations!
- Observe all safety and danger instructions on the wheel assembly trolley!
- Ensure that all safety and danger instructions on the wheel assembly trolley are legible!
- Do not make any changes, additions or modifications to the wheel assembly trolley which may impede the safety without the approval of the manufacturer! This applies in particular to welding load-bearing components.
- Spare parts must conform to the technical requirements specified by the manufacturer. Only original parts can guarantee this.
- Periods prescribed or specified in the operating instructions for cyclic examinations / inspections must be adhered to!
- Switch off and secure the Master Wheel 50 immediately in the event of faults! Rectify any faults immediately!



Operating Instruction

Introduction

2.7 Maintenance work, repairing faults, disposal

- Adhere to the setting, maintenance and inspection work and deadlines specified in the operating instructions, including the replacement of parts and equipment!
This work must only be carried out by qualified personnel.
- Always tighten screw connections that were loosened during maintenance and servicing work!
- Make sure that operating materials, fuels and spare parts are disposed of safely and in an environmentally friendly manner!

2.8 Special dangers

- Separate the charging device from the Master Wheel 50 and the electric mains before the start of repair work.
- Remove voltage from the appliance at all times before the start of repair work; to do this, remove the plug from the battery.
- Do not confuse the electrical connections!

Oils, greases and other chemical substances

Observe the safety instructions that apply to the product when handling oils, greases and other chemical substances!

Applied safety standards

DIN EN 292 / DIN EN 294 / EN 349 /
EN 418 / EN 811 / EN 50099 / EN 1494

3 Technical data

Master Wheel 50

Load bearing capacity	kg	60
Stroke	mm	1400
Weight	kg	60
Length	mm	690
Width	mm	730
Height	mm	1860
Volume	db(A)	<75
Vibration	m/s ²	<2,5
Temperature range	°C	+10 - +40
Wheel dimensions min.	185/80	
Wheel dimensions max.	325/35	

Tab. 1:

Battery set

Quantity	Units	2
Voltage	V	24
Capacity	Ah	7,2

Tab. 2:

Charger

Adapter: EU,US,UK
Primary: 100-240V/ 47-63Hz/65W
Secondary: 24V, 1A, 24W

Tab. 3:

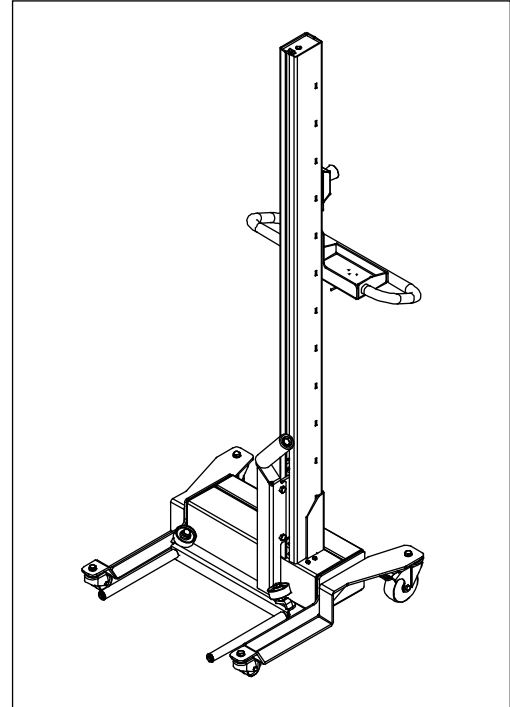

Fig. 1:

Safety installations

- Emergency off
- Up: power limitation 11 A= 60 kg
- Down: power limitation 4 A= 10 kg
- Spindle cover
- Electrical safety 16 A T

Operating Instruction

Transport and assembly

4 Transport and assembly

The Master Wheel 50 is supplied in a carton box ready for operation. A suitable means of transport, e.g. a high-lift truck, is required for transport. Feet, handles and wheel support must be assembled on the basis of the instructions.

4.1 Assembling the feet

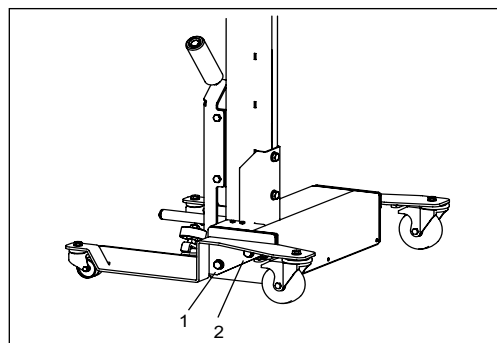

Fig. 2:

- Feet loosely screw on
- Put Mobile Wheel Carriage even on surface place
- Tighten screws (1) and (2) (M12 x 20) with a tightening moment of 60 Nm

4.2 Assembling the sliding handle

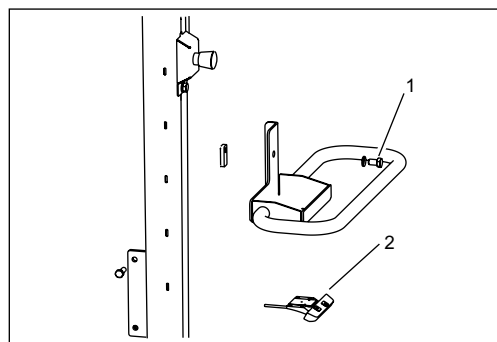

Fig. 3:

- Position the sliding handle at the desired height and connect it using screw (1)
- The operating switch(2) is screwed on beneath the rest.

4.3 Assembling the wheel support

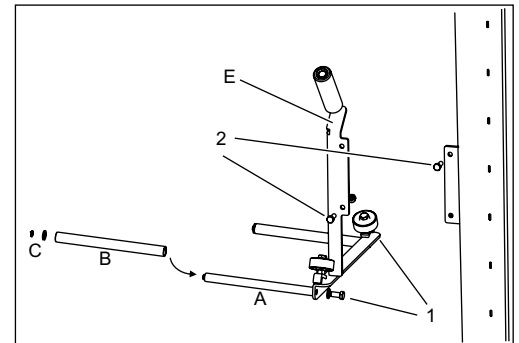

Fig. 4:

- Tighten axle A using screw (1) (M12) with 60 Nm
- Push roller (B) above axle (A) and tighten using (C)
- Tighten the entire wheel support fork (E) using screw (2) (M10) with 40 Nm

5 Commissioning



Warning

Check that the short lifter is complete and in proper working order before the first commissioning! Record the results of the examination in the maintenance plan.

6 Operation

Warning
 Observe all instructions contained in the section "Safety" in these instructions and the valid accident prevention regulations (VBG 1; VBG 14) while operating the Master Wheel 50

- The Master Wheel 50 must only be operated by persons with relevant qualifications.
- Only set the Master Wheel 50 in motion when there is no danger to persons.
- Keep the moving area of the lifter free at all times and ensure that no persons are present in this moving area.
- Do not exceed the maximum load bearing capacity of the Master Wheel 50.
- Do not climb on to the Master Wheel 50, travel with it or climb on to the load!
- Carry out lifting and lowering operations evenly. Observe the load during movement.
- Only use the lifter on a solid base.
- Only load, unload and lift when the brakes are applied to the rollers.

6.1 Charging the battery

Warning
 There is a risk of stumbling or falling over the connecting cable. When charging the battery, always park the Master Wheel against a wall and make sure that the charging cable does not lie across a passageway.

Avoid explosive gases, flames and sparks. Ensure there is sufficient ventilation.

Batteries

The batteries do not require maintenance and can be charged permanently. 100 % load requires 14 hours; a standard load of 85 % requires 6 hours. Always separate the charger from the mains before making or opening the connection to the battery.

Charger

Always use the matching mains plug. The scope of delivery includes plugs for Europe (EU), USA (US) and Great Britain (UK) (item 1).

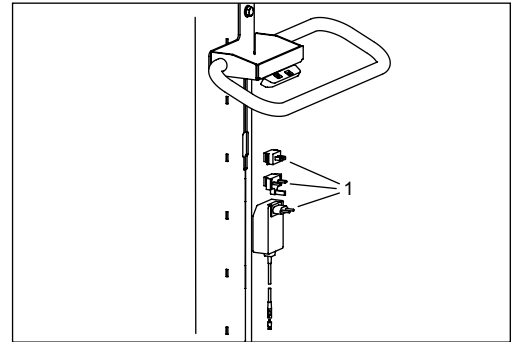

Fig. 5:

LED display on the charger

Red	Charging
Green	Received
Yellow	Battery polarity inverted

Tab. 4:

6.2 Loading and unloading

Position the wheel in such a way that the outside of the rim points towards the lifting mast and lies against the rollers. Before lifting or lowering, make sure that the wheel is lying securely, cannot fall off and that the rim is not damaged during turning.

6.3 Transporting the load

Warning
 Risk of falling due to unfavourable position of centre of gravity, uneven floor or obstacles.

- Always completely lower the load for transporting.
- Only transport loads on an even and solid floor that is free of obstacles.

6.4 Lifting loads

- Lightly press button “Lift” (1) and slightly lift the wheel.
- Check that the wheel is held securely.
- Now fully press the button “Lift” (1) and lift the wheel to the desired height.

6.5 Lowering loads

- Check that the wheel is held securely.
- Fully press the button “Lower” (2) and lower the wheel.

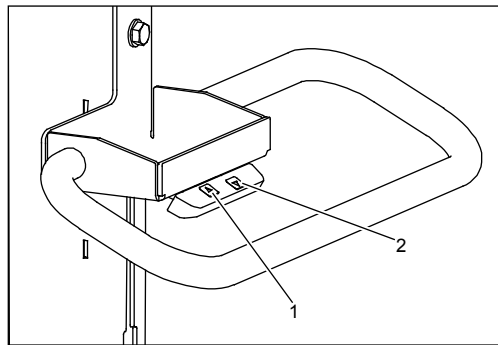

Fig. 6:

Please contact the manufacturer for additional information on all accessories for carrying and supporting loads.

BlitzRotary GmbH
Hüfinger Straße 55
D-78199 Bräunlingen
Phone +49.771.9233.0
Fax +49.771.9233.99
info@blitzrotary.com
www.blitzrotary.com

Operating Instruction

Faults / causes / rectification

7 Faults / causes / rectification

There may be simple reasons if the lifter does not work properly. Please check the possible causes as specified on the following pages. Call our technical service if you are unable to define the source of the problem.



Warning

Only qualified persons may carry out repairs on safety installations of the lifter

Unloaded: no function up/down

Possible causes	Rectification
Battery empty	<ul style="list-style-type: none"> • Charge battery
Battery defect	<ul style="list-style-type: none"> • Check battery voltage. The battery voltage should be 2x12V.
Charger defect	<ul style="list-style-type: none"> • Check the connections from and to the charger. • Check the display on the charger.
Fuse	<ul style="list-style-type: none"> • Check: There is a fuse 16A T on the motor control printed circuit board (replace if necessary)

With load: no function up/down

Possible causes	Rectification
Maximum load exceeded	<ul style="list-style-type: none"> • Check unloaded • Continue examination as mentioned under above point

Geräusche beim Anheben

Possible causes	Rectification
Dirt, lubrication	<ul style="list-style-type: none"> Remove spindle cover and lubricate the shaft and pillar guide.

8 Maintenance and repair

The operator must carry out regular servicing every 3 months. If the appliance is in permanent operation or in a particularly dirty environment, shorten the maintenance intervals accordingly.

Observe correct functions during operation. Request technical service if there is any doubt.

- Only qualified personnel may carry out maintenance and repair work.
- Maintenance and repair work on the Master Wheel 50 may only be carried out when it is unloaded.
- Always tighten screw connections that were loosened as part of maintenance or servicing work!
- Make sure that operating materials, fuels and spare parts are disposed of safely and in an environmentally friendly manner!
- Separate the appliance from the electrical mains before the start of maintenance and repair work!
- Examine the wheel assembly trolley after the end of all maintenance and repair work and record the results in the examination log!

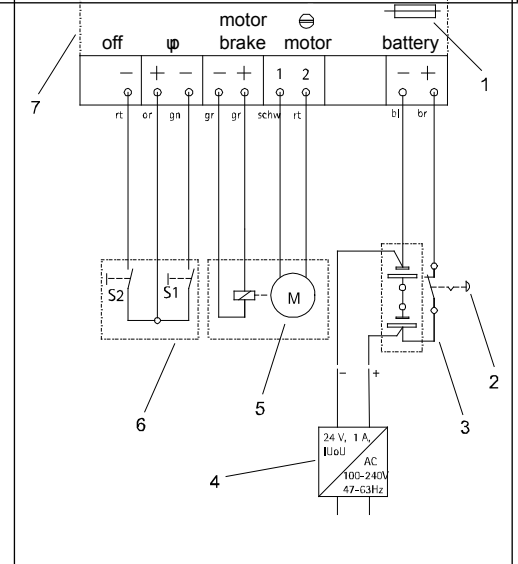

Fig. 7:

Pos.	Qty.	Description
1	1	Fuse 16A
2	1	Emergency off
3	2	Battery 12V
4	1	Charger
5	1	Gear motor 24V
7	1	Operating switch
8	1	Control

Tab. 4:

8.1 Electrical circuit diagram

Periodic work
Daily

- Charge battery
- Clean

Every 3 months

- Check charger.
- Check rollers.
- Check emergency off.
- Check that all nuts and bolts are tight.
- Grease lifting spindle.
- Grease guides.
- Grease rollers on the load support.

Whenever necessary

- Replace batteries.

8.3 Description of periodic work

Warning

Risk due to unexpected activation.

Before the start of the periodic work:

- Separate the appliance from the electrical mains.
- Press the emergency off switch
- Open the cover and remove the battery plug.

Cleaning

- Do not use high-pressure cleaners.
- Use standard detergents for cleaning, observe the instructions issued by the detergent manufacturer.
- Rub the appliance dry after cleaning.

Checking the charger

- Remove the voltage from the appliance; to do this, pull the mains plug and the charging cable.
- Check the cables for damage and wear.

Checking the rollers

- All rollers must turn easily.
- Check the braking function on the steering rollers.
- Check that all screws on the rollers are tight.

Checking the emergency off

- Function test

Grease the lifting spindle and the guides

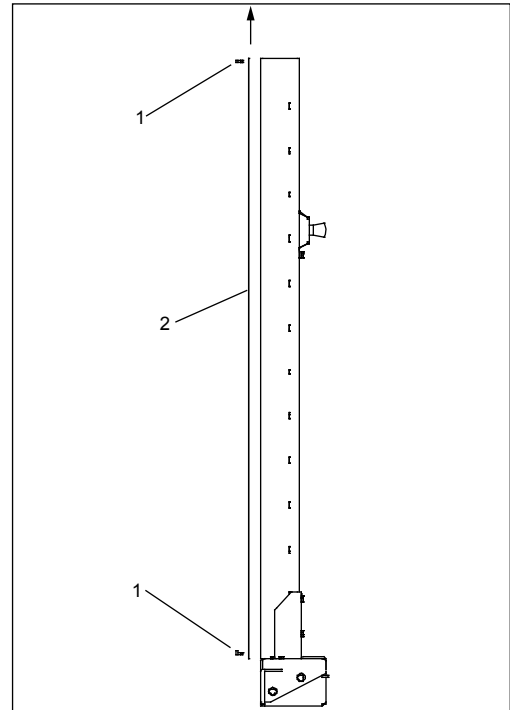

Fig. 8:

- Separate the appliance from the electrical mains before the start.
- Open the cover and pull the battery plug.
- Press the emergency off switch.
- Release screws (1) and push the cover rail (2) upwards.
- Dismantle the spindle cover.
- Grease the spindle and guide tracks on the inside of the pillar slightly.
- Assemble the spindle cover.
- Place the covering track (2) from above and tighten screw (1).
- Replace the upper connecting screw and then the lower connecting screw while the appliance is standing.

Greasing load support rollers

- All rollers must run easily.

Replacing the battery

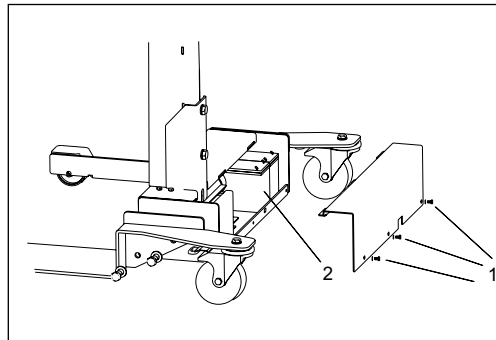

Fig. 9:

- Open the cover by releasing the screws (1)
- Pull the cable plug
- Remove batteries (2)
- Replace new batteries
- Replace the plug, do not confuse the connections
- Close the cover once more by tightening the screws (1).
- Dispose of old batteries properly.



9 Safety examination

The safety examination is necessary to guarantee the safety of the Master Wheel upon commissioning. This must be carried out and certified in specified cases by a qualified person.

- First safety examination: manufacturer carries it out before commissioning.
- Regular safety examination: in regular intervals after first commissioning, at least once a year.
- Extraordinary safety examination: after construction changes to the wheel assembly trolley.

11 Appendix

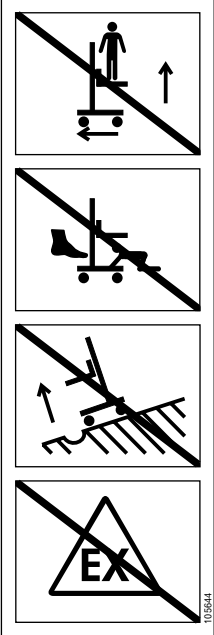
11.1 Adhesive notices

Order No.	
105644	
105645	<div style="border: 1px solid black; padding: 5px; display: flex; align-items: center; justify-content: center;"> max. 60 kg </div>
3600011	



Operating Instruction

Appendix

11.2 Safety examination

Master Wheel 50

Serial No.	Year of construction
-------------------	-----------------------------

Test steps for the safety examination

- Nameplate attached and labelling in place
- Warning signs in place (load bearing capacity and warning instructions)
- Check supporting construction for deformation and cracks
- Check that all supporting screws are tight
- Check state of the electrical wires
- Check charger (cable and plug)
- Check function of the emergency off switch
- Function test with load

First safety examination carried out by manufacturer, no faults identified

BlitzRotary GmbH	
-------------------------	---

Regular safety examination

Date	Signature/Expert	No faults	Faults	Additional examination required



BlitzRotary GmbH

Hüfinger Straße 55
D-78199 Bräunlingen
Telefon +49.771.9233.0
Telefax +49.771.9233.99
info@blitzrotary.com
www.blitzrotary.com

